

CHT-7408 DATASHEET

Revision: 3.8
10-Dec-23
(Last Modified Date)

High-Temperature, Quad 2-Inputs AND Gate

General Description

The CHT-7408 contains four independent 2-inputs AND gates, performing the Boolean function :

$$Y = A \cdot B$$

This circuit is designed assuring latchup-free operation for all supply and temperature conditions.

The CHT-7408 can operate with supply voltages from 3.3 to 5V ($\pm 10\%$).

Features

- Qualified from -55 to +225°C (Tj)
- 3.3 to 5V ($\pm 10\%$) supply voltages
- Latchup-free at any supply and temperature condition
- Validated at 225°C for 30000 hours (CDIL14) and 20000 hours (CSOIC16) (and still on-going)
- Available in DIL14 and CSOIC16 hermetic standard package

Applications

- Well logging,
- Automotive, Aeronautics & Aerospace
- Harsh Environments

Package and Pin Configuration

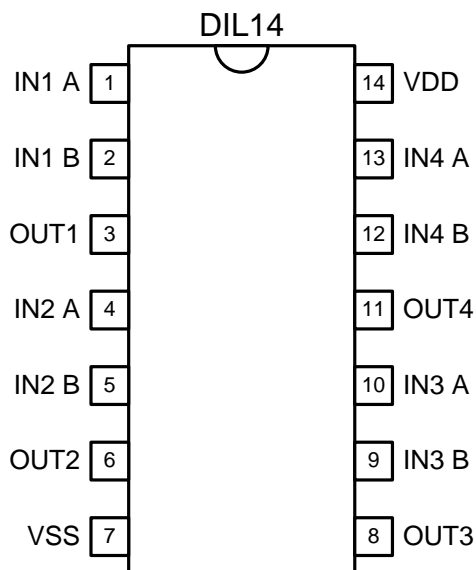

Pin	Symbol	Description
1	IN1 A	Input A of the AND gate number 1
2	IN1 B	Input B of the AND gate number 1
3	OUT1	Output of the AND gate number 1
4	IN2 A	Input A of the AND gate number 2
5	IN2 B	Input B of the AND gate number 2
6	OUT2	Output of the AND gate number 2
7	VSS	Circuit core ground terminal.
8	OUT3	Output of the AND gate number 3
9	IN3 B	Input B of the AND gate number 3
10	IN3 A	Input A of the AND gate number 3
11	OUT4	Output of the AND gate number 4
12	IN4 B	Input B of the AND gate number 4
13	IN4 A	Input A of the AND gate number 4
14	VDD	Circuit core power supply terminal.

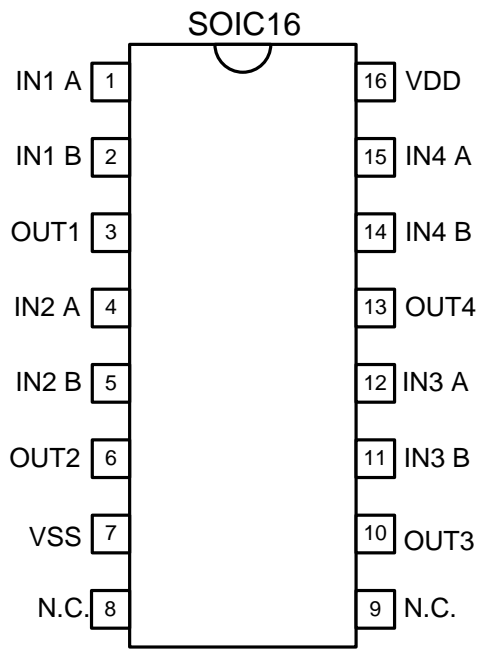

Pin	Symbol	Description
1	IN1 A	Input A of the AND gate number 1
2	IN1 B	Input B of the AND gate number 1
3	OUT1	Output of the AND gate number 1
4	IN2 A	Input A of the AND gate number 2
5	IN2 B	Input B of the AND gate number 2
6	OUT2	Output of the AND gate number 2
7	VSS	Circuit core ground terminal.
8	N.C.	No connected terminal.
9	N.C.	No connected terminal.
10	OUT3	Output of the AND gate number 3
11	IN3 B	Input B of the AND gate number 3
12	IN3 A	Input A of the AND gate number 3
13	OUT4	Output of the AND gate number 4
14	IN4 B	Input B of the AND gate number 4
15	IN4 A	Input A of the AND gate number 4
16	VDD	Circuit core power supply terminal.

Function Table

INPUT		OUTPUT
A	B	Y
L	L	L
L	H	L
H	L	L
H	H	H

Function and Logical Diagrams

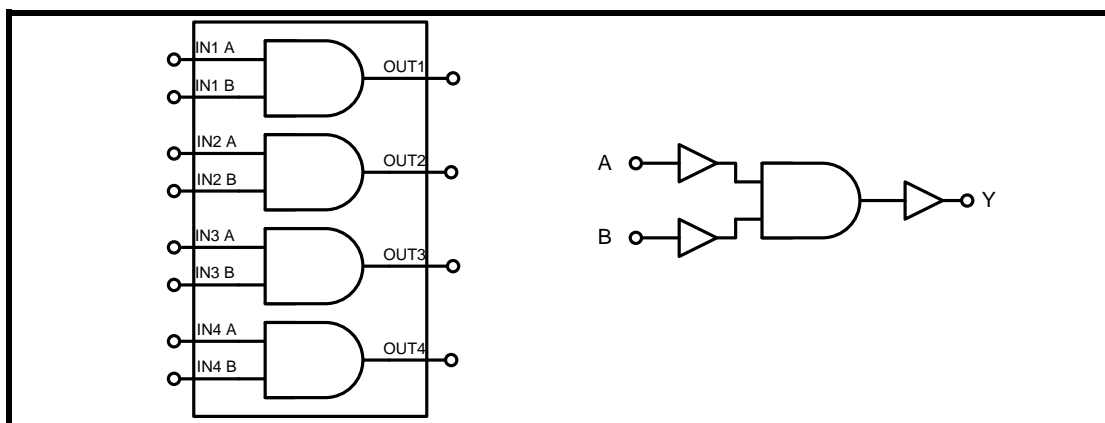

Figure 1. CHT-7408: simplified block diagram.

Absolute Maximum Ratings

Supply Voltage V_{DD} to GND -0.7 to 6.0V
 Voltage on any Pin to GND -0.5 to $V_{DD}+0.5V$

ESD Rating (expected)

Human Body Model 1kV

Operating Conditions

Supply Voltage V_{DD} to GND 3.3V to 5V ($\pm 10\%$)
 Junction temperature -55°C to +225°C

DC Electrical Characteristics

Unless otherwise stated: $V_{DD}=5V$, $T_j=25^\circ C$. **Bold underlined** figures indicate values valid over the whole temperature range ($-55^\circ C < T_j < +225^\circ C$).

Parameter	Condition	Min	Typ	Max	Units
Supply voltage V_{DD}		2.97		5.5V	V
Quiescent current I_{DD}	$V_{DD} = 3.3V$, $T_j = -55^\circ C$			4	nA
	$V_{DD} = 5V$, $T_j = -55^\circ C$			13	
	$V_{DD} = 3.3V$, $T_j = 225^\circ C$			<u>2990</u>	
	$V_{DD} = 5V$, $T_j = 225^\circ C$			<u>3500</u>	
Minimum HIGH level output voltage V_{OH}	$V_{DD} = 3.3V$, $I_{OH} < 4mA$ (source)	<u>2.7</u>	3.04		V
	$V_{DD} = 5V$, $I_{OH} < 4mA$ (source)	<u>4.6</u>	4.82		
Maximum LOW level output voltage V_{OL}	$V_{DD} = 3.3V$, $I_{OL} < 4mA$ (sink)		0.28	<u>0.5</u>	V
	$V_{DD} = 5V$, $I_{OL} < 4mA$ (sink)		0.20	<u>0.4</u>	
Minimum HIGH level input voltage V_{IH}	$V_{DD} = 3.3V$	<u>2.4</u>	2.10		V
	$V_{DD} = 5V$	<u>3.7</u>	3.49		
Maximum LOW level input voltage V_{IL}	$V_{DD} = 3.3V$		1.72	<u>1.5</u>	V
	$V_{DD} = 5V$		2.16	<u>2.0</u>	
Input leakage current (source / sink) $\pm I_I$	$V_I = V_{CC}$ or GND, $V_{DD} = 3.3V$		± 1	<u>± 35</u>	nA
	$V_I = V_{CC}$ or GND, $V_{DD} = 5V$		± 2	<u>± 37</u>	

AC Electrical Characteristics

Unless otherwise stated: VDD=5V, T_j=25°C. **Bold underlined** figures indicate values valid over the whole temperature range (-55°C < T_j < +225°C).

Parameter	Condition	Temperature	Min	Typ	Max	Units
Propagation delay time from A or B to Y ¹ t _{PHL}	C _L =50pF	T _j =-55°C		9	16	ns
		T _j =25°C		10	18	
		T _j =225°C		14	<u>25</u>	
Propagation delay time from A or B to Y t _{PLH}	C _L =50pF	T _j =-55°C		9	16	ns
		T _j =25°C		10	18	
		T _j =225°C		13	<u>23</u>	
Output transition time High to Low t _{THL}	C _L =50pF	T _j =-55°C		13	17	ns
		T _j =25°C		14	18	
		T _j =225°C		17	<u>22</u>	
Output transition time Low to High t _{TLH}	C _L =50pF	T _j =-55°C		19	25	ns
		T _j =25°C		20	26	
		T _j =225°C		23	<u>30</u>	

¹ Input A is 1% to 2% faster than input B.

AC Electrical Characteristics (cntd)

Unless otherwise stated: $V_{DD}=3.3V$, $T_j=25^\circ C$. **Bold underlined** figures indicate values valid over the whole temperature range ($-55^\circ C < T_j < +225^\circ C$).

Parameter	Condition	Temperature	Min	Typ	Max	Units
Propagation delay time from A or B to Y t_{PHL}	$C_L=50pF$	$T_j=-55^\circ C$		16	28	ns
		$T_j=25^\circ C$		19	33	
		$T_j=225^\circ C$		23	<u>40</u>	
Propagation delay time from A or B to Y t_{PLH}	$C_L=50pF$	$T_j=-55^\circ C$		17	30	ns
		$T_j=25^\circ C$		19	33	
		$T_j=225^\circ C$		23	<u>40</u>	
Output transition time High to Low t_{THL}	$C_L=50pF$	$T_j=-55^\circ C$		20	26	ns
		$T_j=25^\circ C$		21	28	
		$T_j=225^\circ C$		27	<u>36</u>	
Output transition time High to Low t_{TLH}	$C_L=50pF$	$T_j=-55^\circ C$		23	30	ns
		$T_j=25^\circ C$		24	32	
		$T_j=225^\circ C$		26	<u>34</u>	

AC Waveforms

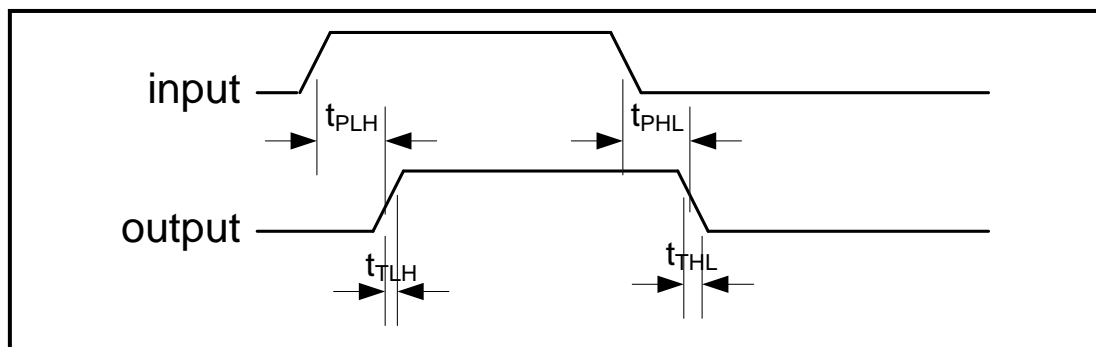
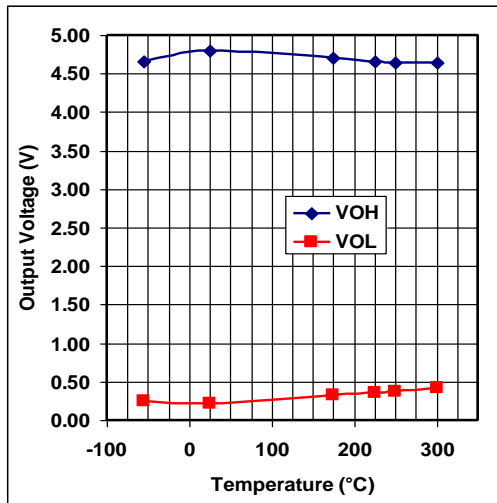
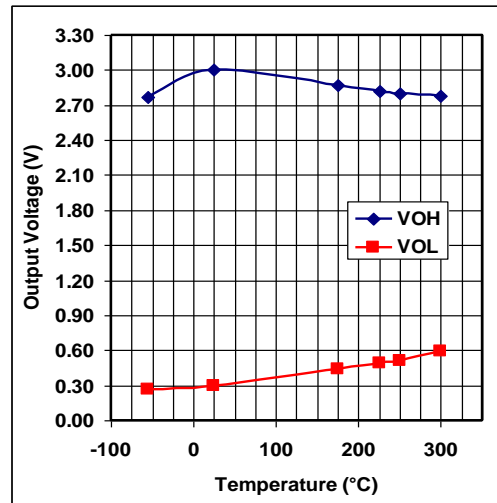

Figure 2. AC Waveforms

Typical Performance Characteristics



Output voltage levels versus temperature,
 $V_{DD} = 5V$



Output voltage levels versus temperature,
 $V_{DD} = 3.3V$

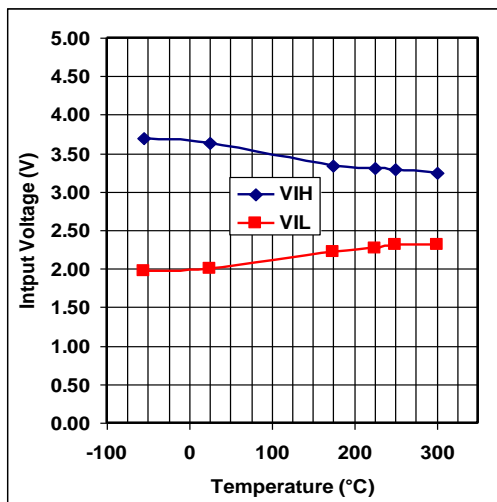

Input voltage levels versus temperature,
 $V_{DD} = 5V$

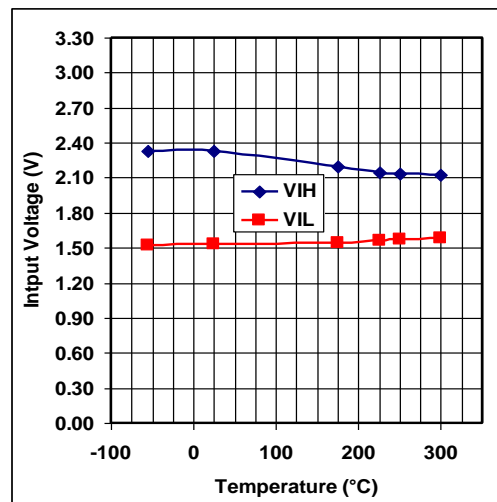

Input voltage levels versus temperature,
 $V_{DD} = 3.3V$

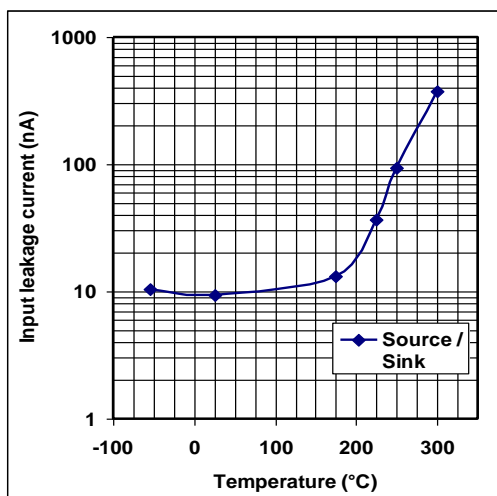

Input leakage current versus temperature,
 $V_{DD} = 5V$

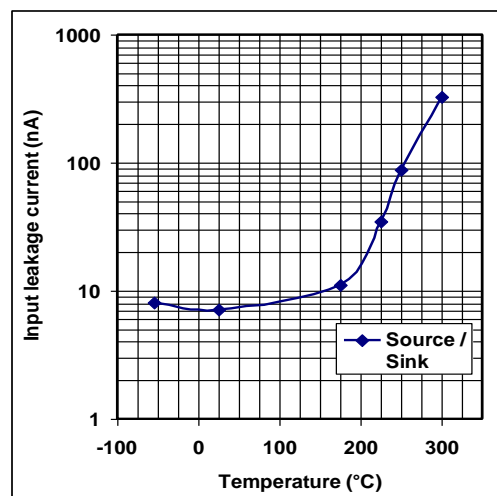

Input leakage current versus temperature,
 $V_{DD} = 3.3V$

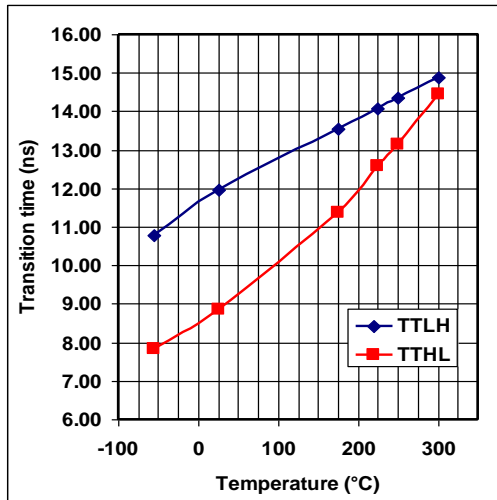

Transition times versus temperature,
 $V_{DD} = 5V$

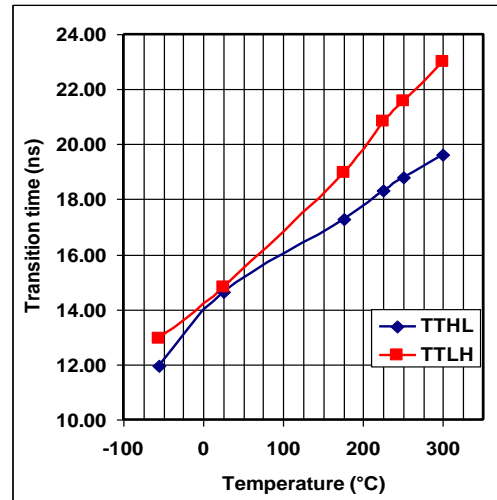

Transition times versus temperature,
 $V_{DD} = 3.3V$

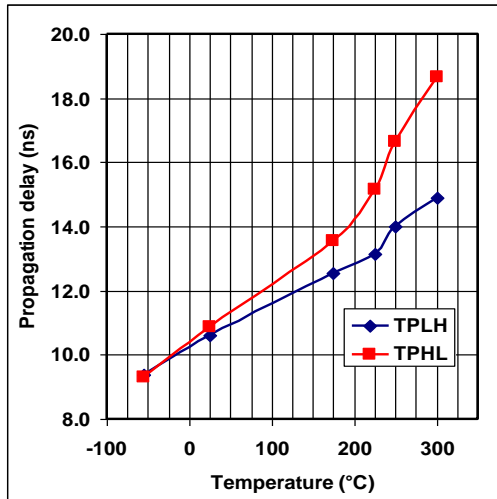

Propagation delays versus temperature,
 $V_{DD} = 5V$

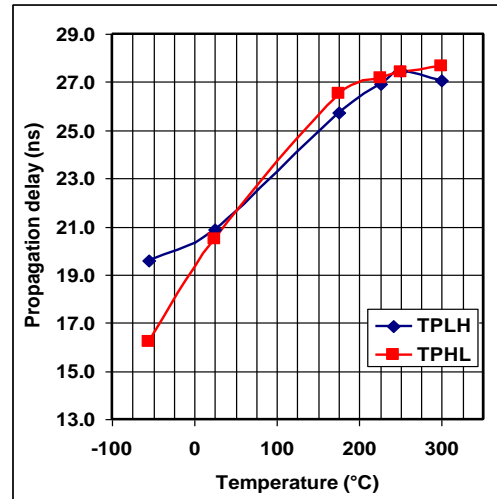

Propagation delays versus temperature,
 $V_{DD} = 3.3V$

Ordering Information

Ordering Reference	Package	Temperature Range	Marking	Status
CHT-7408-CDIL14-T	Ceramic DIL14	-55°C to +225°C	CHT-7408	Not for new design
CHT-7408-CSOIC16-T	Ceramic SOIC16	-55°C to +225°C	CHT-7408	

Package Dimensions

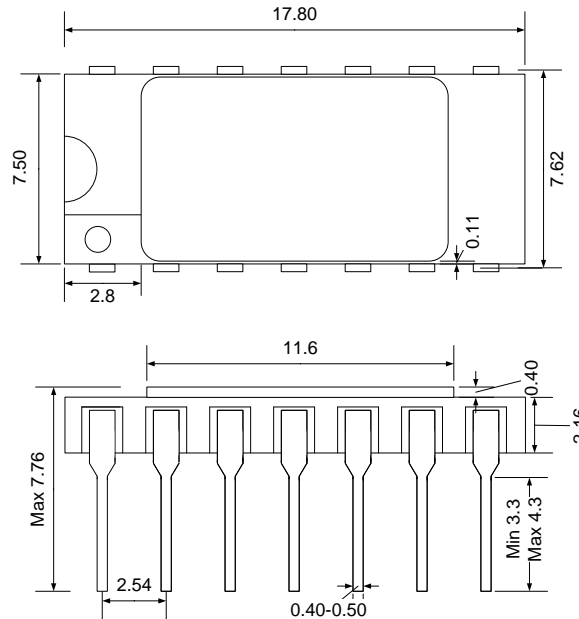

Drawing CDIL14 (mm +/- 10%)

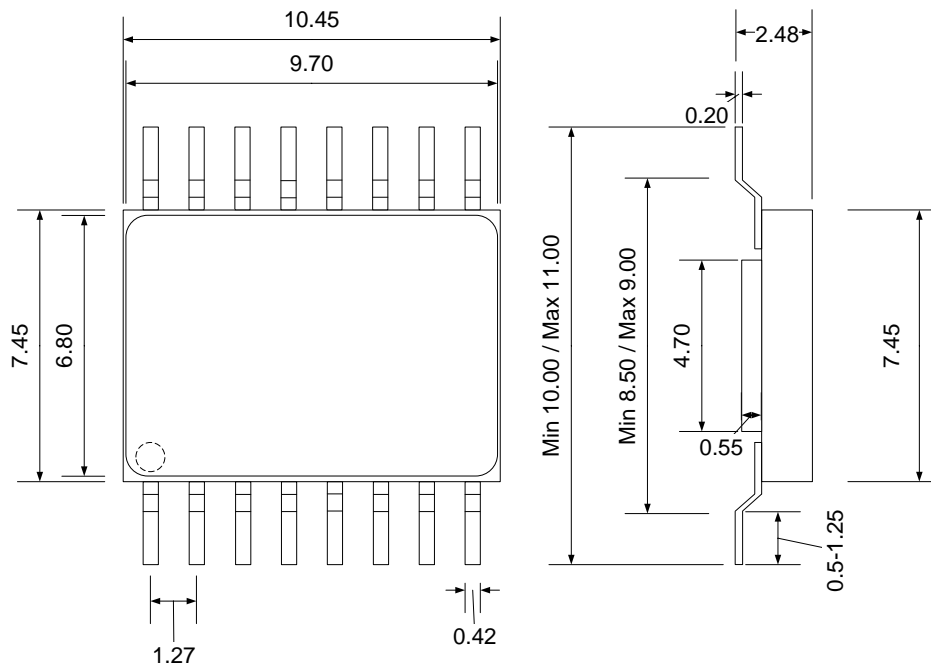

Drawing CSOIC16 (mm +/- 10%)

Contact & Ordering

CISSOID S.A.

Headquarters and contact EMEA:	CISSOID S.A. – Rue Francqui, 11 – 1435 Mont Saint Guibert - Belgium T : +32 10 48 92 10 - F: +32 10 88 98 75 Email: sales@cissoid.com
Representatives	Visit our website: www.cissoid.com

Disclaimer

Neither CISSOID, nor any of its directors, employees or affiliates make any representations or extend any warranties of any kind, either express or implied, including but not limited to warranties of merchantability, fitness for a particular purpose, and the absence of latent or other defects, whether or not discoverable. In no event shall CISSOID, its directors, employees and affiliates be liable for direct, indirect, special, incidental or consequential damages of any kind arising out of the use of its circuits and their documentation, even if they have been advised of the possibility of such a damage. The circuits are provided "as is". CISSOID has no obligation to provide maintenance, support, updates, or modifications.