

CMT-74-4040-DATASHEET

Version: 1.1
10-Dec-23
(Last Modification Date)

High Temperature, 12 stage binary counter

General Description

The CMT-74-4040 is a 12-stage asynchronous binary counter.

The device is incremented on the falling edge (negative transition) of the CLOCK input. All the outputs are reset to a low level by applying a logical high on the CLEAR input.

In frequency divider applications, the clock can be divided by up to 4096.

The device is pin compatible with the industry standards 74xx4040, / CD4040. As such, CISSOID CMT-74-4040 can replace advantageously the above devices and bring a lifetime increase of 1 to 2 decades depending on the temperature range; it also increases the operating temperature capability to -55~+175°C which cannot be achieved by traditional products.

The CMT-74-4040 can operate with supply voltages from 3.3 to 5V (±10%).

Features

- Functional from -55 to +175°C (Tj)
- 3.3 to 5V (±10%) supply voltages
- Latchup-free at any supply and temperature condition
- Available in plastic SOI16 standard package
- Typical propagation delay: 19 ns
- Low quiescent current: 21µA Max (@175°C, 5V)
- Output drive capability: 4mA Max
- Validated at 175°C for 1000 hours (and still on-going)

Applications

- Clock generation
- Frequency division

Package and Pin Configuration

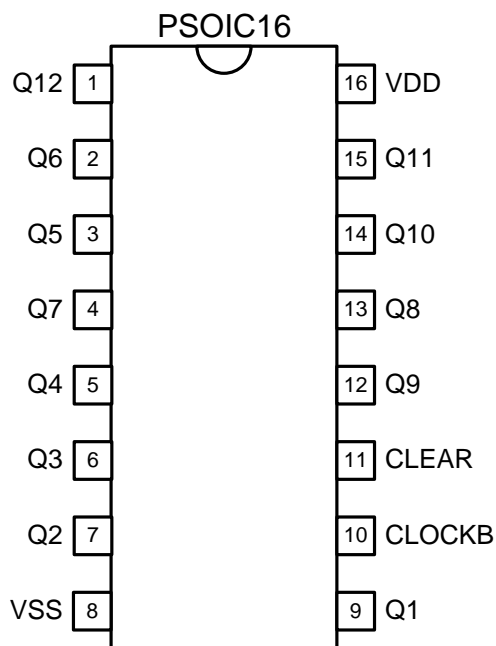

Pin	Symbol	Description
1	Q12	Parallel output <12>
2	Q6	Parallel output <6>
3	Q5	Parallel output <5>
4	Q7	Parallel output <7>
5	Q4	Parallel output <4>
6	Q3	Parallel output <3>
7	Q2	Parallel output <2>
8	VSS	Negative power supply
9	Q1	Parallel output <1>
10	CLOCKB	Clock input (HIGH to LOW, edge triggered)
11	CLEAR	Reset input (active HIGH)
12	Q9	Parallel output <9>
13	Q8	Parallel output <8>
14	Q10	Parallel output <10>
15	Q11	Parallel output <11>
16	VDD	Positive power supply

Function Table

CLOCKB	CLEAR	OUTPUT STATE
X	H	All "LOW"
Rising edge	L	NO CHANGE
Falling edge	L	INCREMENT by "one"

Function and Logical Diagrams

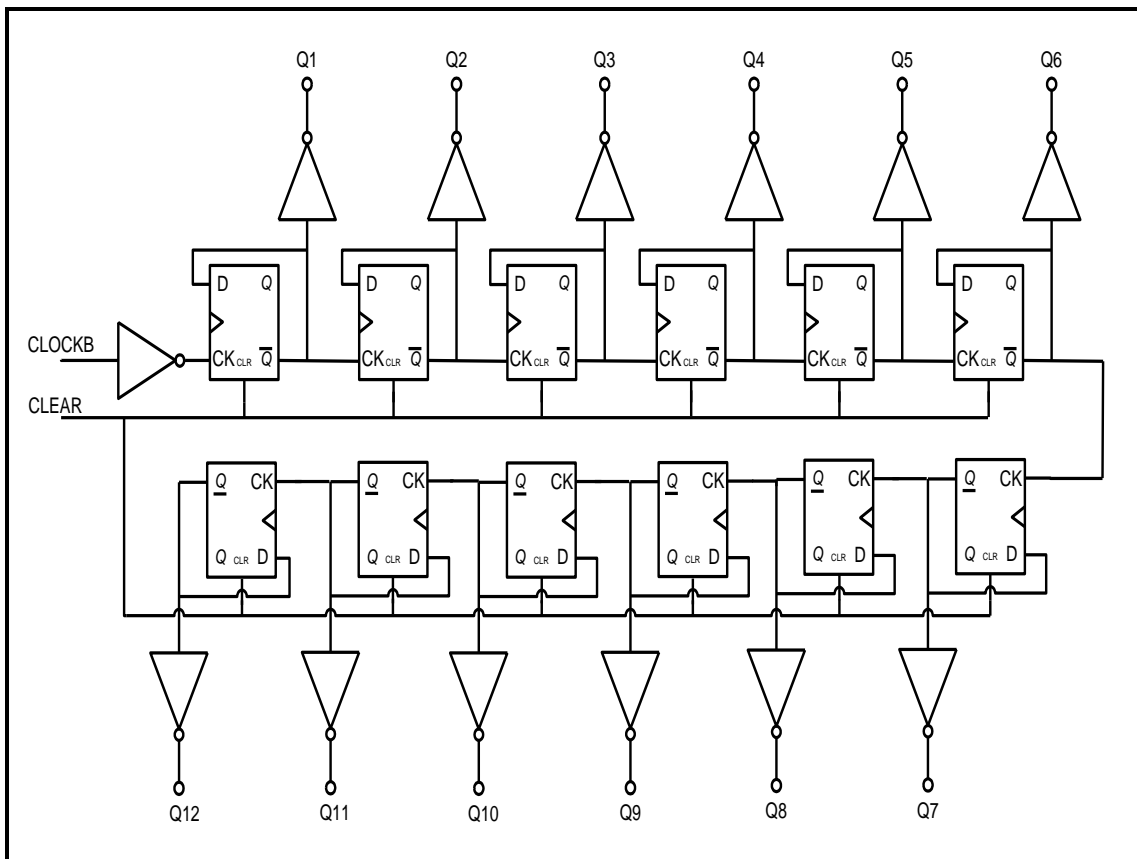

Figure 1. CMT-74-4040: simplified block diagram.

Absolute Maximum Ratings

Supply Voltage V_{DD} to GND -0.5 to 5.5V
Voltage on any Pin to GND -0.5 to $V_{DD}+0.5V$

ESD Rating

Human Body Model Class 2

Operating Conditions

Supply Voltage V_{DD} to GND 3.3V to 5V ($\pm 10\%$)
Junction temperature -55°C to +175°C
Voltage on any input pin 0V to VDD

DC Electrical Characteristics

Unless otherwise stated: $T_j=25^{\circ}\text{C}$. **Bold** figures indicate values valid over the whole temperature range ($-55^{\circ}\text{C} < T_j < +175^{\circ}\text{C}$).

Parameter	Condition	Min	Typ	Max	Units
Supply voltage V_{DD}			5		V
Quiescent current I_{DD}	$T_j=-55^{\circ}\text{C}$			30	nA
	$T_j=175^{\circ}\text{C}$			21	μA
Minimum HIGH level output voltage V_{OH}	$I_{OH}<4\text{mA}$ (source)	4.67	4.82		V
Maximum LOW level output voltage V_{OL}	$I_{OL}<4\text{mA}$ (sink)		0.2	0.4	V
Minimum HIGH level input voltage V_{IH}		3.7	3.49		V
Maximum LOW level input voltage V_{IL}			2.16	2	V

Parameter	Condition	Min	Typ	Max	Units
Supply voltage V_{DD}			3.3		V
Quiescent current I_{DD}	$T_j=-55^{\circ}\text{C}$			20	nA
	$T_j=175^{\circ}\text{C}$			21	μA
Minimum HIGH level output voltage V_{OH}	$I_{OH}<4\text{mA}$ (source)	2.91	3.03		V
Maximum LOW level output voltage V_{OL}	$I_{OL}<4\text{mA}$ (sink)		0.28	0.5	V
Minimum HIGH level input voltage V_{IH}		2.4	2.1		V
Maximum LOW level input voltage V_{IL}			1.72	1.5	V

AC Electrical Characteristics

Unless otherwise stated: VDD=5V, $T_j=25^\circ\text{C}$. **Bold** figures indicate values valid over the whole temperature range ($-55^\circ\text{C} < T_j < +175^\circ\text{C}$).

Parameter	Condition	Temperature	Min	Typ	Max	Units
Output transition time t_{THL}, t_{TLH}	$C_L=50\text{pF}$, Input $t_r=t_f=6\text{ns}$	$T_j=-55^\circ\text{C}$	5.5	6.9	9	ns
		$T_j=25^\circ\text{C}$	6.7	8.6	11.1	
		$T_j=175^\circ\text{C}$	9.8	13.2	18.2	
Propagation delay time ($Q_n \Rightarrow Q_{n+1}$) t_{PHL}, t_{PLH}	$C_L=50\text{pF}$, Input $t_r=t_f=6\text{ns}$	$T_j=-55^\circ\text{C}$	2.3	3.3	4.7	ns
		$T_j=25^\circ\text{C}$	3	4.4	6.32	
		$T_j=175^\circ\text{C}$	4.8	7.3	10.7	
Propagation delay time (CLOCKB \Rightarrow Q1) t_{PHL}, t_{PLH}	$C_L=50\text{pF}$, Input $t_r=t_f=6\text{ns}$	$T_j=-55^\circ\text{C}$	11.6	15.7	21.7	ns
		$T_j=25^\circ\text{C}$	14.2	19	27.5	
		$T_j=175^\circ\text{C}$	20.8	29.7	43	
Propagation delay time (CLEAR \Rightarrow Qn) t_{PHL}, t_{PLH}	$C_L=50\text{pF}$, Input $t_r=t_f=6\text{ns}$	$T_j=-55^\circ\text{C}$	14.3	19.1	26	ns
		$T_j=25^\circ\text{C}$	16.9	23.2	32.5	
		$T_j=175^\circ\text{C}$	24.2	34.6	49.6	
Max clock frequency f_{MAX}	$C_L=50\text{pF}$, Input $t_r=t_f=6\text{ns}$	$T_j=-55^\circ\text{C}$		30.0		MHz
		$T_j=25^\circ\text{C}$		23.8		
		$T_j=175^\circ\text{C}$		15.6		
Minimum pulse width (CLOCKB) t_{WH}, t_{WL}	$C_L=50\text{pF}$, Input $t_r=t_f=6\text{ns}$	$T_j=-55^\circ\text{C}$	12			ns
		$T_j=25^\circ\text{C}$	18			
		$T_j=175^\circ\text{C}$	22			
Minimum pulse width (CLEAR) t_{WH}	$C_L=50\text{pF}$, Input $t_r=t_f=6\text{ns}$	$T_j=-55^\circ\text{C}$	8			ns
		$T_j=25^\circ\text{C}$	8			
		$T_j=175^\circ\text{C}$	12			
Minimum setup time (CLEAR \Leftrightarrow CLOCK) t_s	$C_L=50\text{pF}$, Input $t_r=t_f=6\text{ns}$	$T_j=-55^\circ\text{C}$	6			ns
		$T_j=25^\circ\text{C}$	7			
		$T_j=175^\circ\text{C}$	11			

AC Electrical Characteristics

Unless otherwise stated: VDD=3.3V, $T_j=25^\circ\text{C}$. **Bold** figures indicate values valid over the whole temperature range ($-55^\circ\text{C} < T_j < +175^\circ\text{C}$).

Parameter	Condition	Temperature	Min	Typ	Max	Units
Output transition time t_{THL}, t_{TLH}	$C_L=50\text{pF}$, Input $t_r=t_f=6\text{ns}$	$T_j=-55^\circ\text{C}$	8.8	12.7	19.5	ns
		$T_j=25^\circ\text{C}$	10.7	16	24.3	
		$T_j=175^\circ\text{C}$	15	22.6	33.6	
Propagation delay time ($Q_n \Rightarrow Q_{n+1}$) t_{PHL}, t_{PLH}	$C_L=50\text{pF}$, Input $t_r=t_f=6\text{ns}$	$T_j=-55^\circ\text{C}$	4.2	6.8	11.4	ns
		$T_j=25^\circ\text{C}$	5.4	9	14.9	
		$T_j=175^\circ\text{C}$	8	13	21.4	
Propagation delay time (CLOCKB \Rightarrow Q1) t_{PHL}, t_{PLH}	$C_L=50\text{pF}$, Input $t_r=t_f=6\text{ns}$	$T_j=-55^\circ\text{C}$	20.5	32	51.2	ns
		$T_j=25^\circ\text{C}$	24.7	38.6	62.1	
		$T_j=175^\circ\text{C}$	33.4	52.8	84.2	
Propagation delay time (CLEAR \Rightarrow Qn) t_{PHL}, t_{PLH}	$C_L=50\text{pF}$, Input $t_r=t_f=6\text{ns}$	$T_j=-55^\circ\text{C}$	25.6	39.3	62.5	ns
		$T_j=25^\circ\text{C}$	30	46.4	74.2	
		$T_j=175^\circ\text{C}$	39.6	62.3	99.1	
Max clock frequency f_{MAX}	$C_L=50\text{pF}$, Input $t_r=t_f=6\text{ns}$	$T_j=-55^\circ\text{C}$		14.2		MHz
		$T_j=25^\circ\text{C}$		11.6		
		$T_j=175^\circ\text{C}$		8.5		
Minimum pulse width (CLOCKB) t_{WH}, t_{WL}	$C_L=50\text{pF}$, Input $t_r=t_f=6\text{ns}$	$T_j=-55^\circ\text{C}$	23			ns
		$T_j=25^\circ\text{C}$	32			
		$T_j=175^\circ\text{C}$	40			
Minimum pulse width (CLEAR) t_{WH}	$C_L=50\text{pF}$, Input $t_r=t_f=6\text{ns}$	$T_j=-55^\circ\text{C}$	16			ns
		$T_j=25^\circ\text{C}$	21			
		$T_j=175^\circ\text{C}$	25			
Minimum setup time (CLEAR \leftrightarrow CLOCK) t_s	$C_L=50\text{pF}$, Input $t_r=t_f=6\text{ns}$	$T_j=-55^\circ\text{C}$	14			ns
		$T_j=25^\circ\text{C}$	17			
		$T_j=175^\circ\text{C}$	22			

AC Waveforms

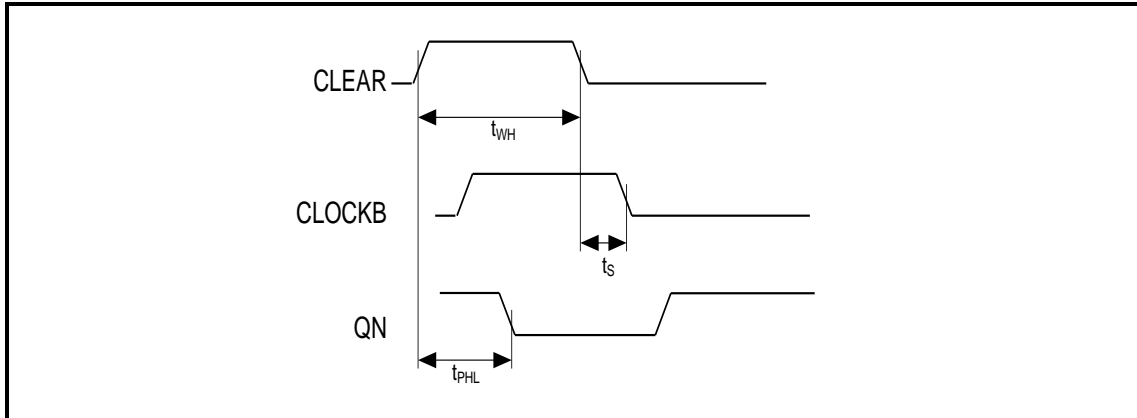

Figure 2. Waveform: minimum pulse width (CLEAR) and setup time (CLEAR to CLOCKB)

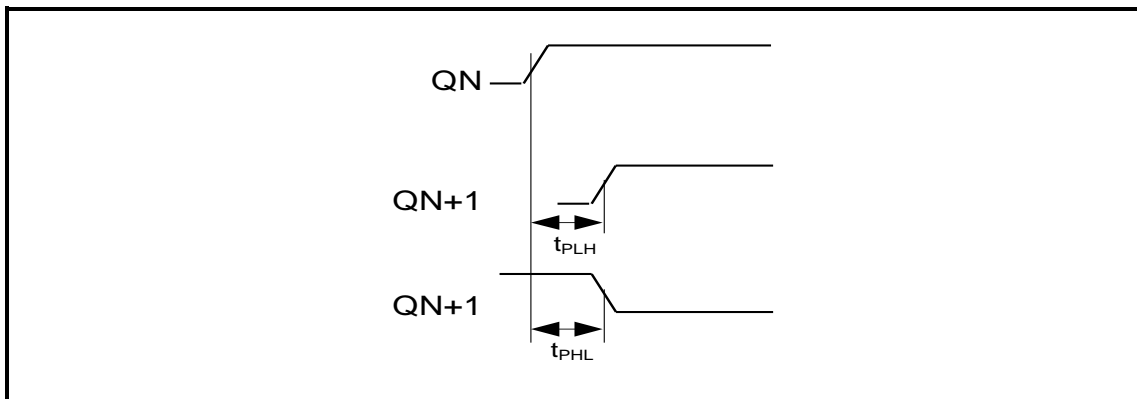

Figure 3. Waveform: propagation delay time

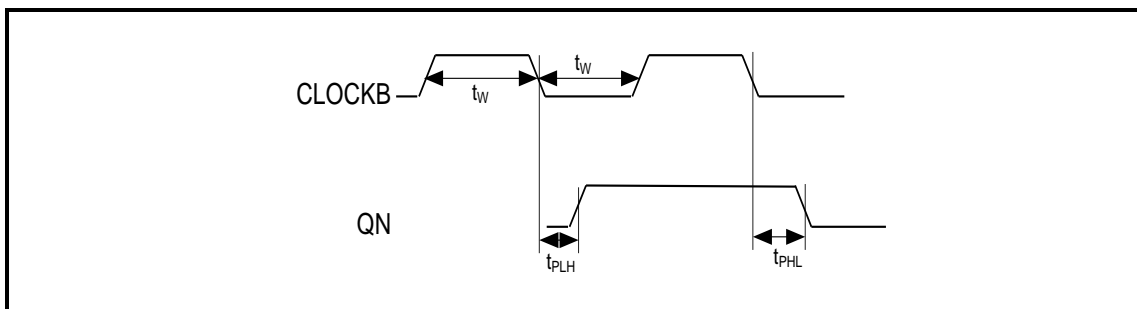
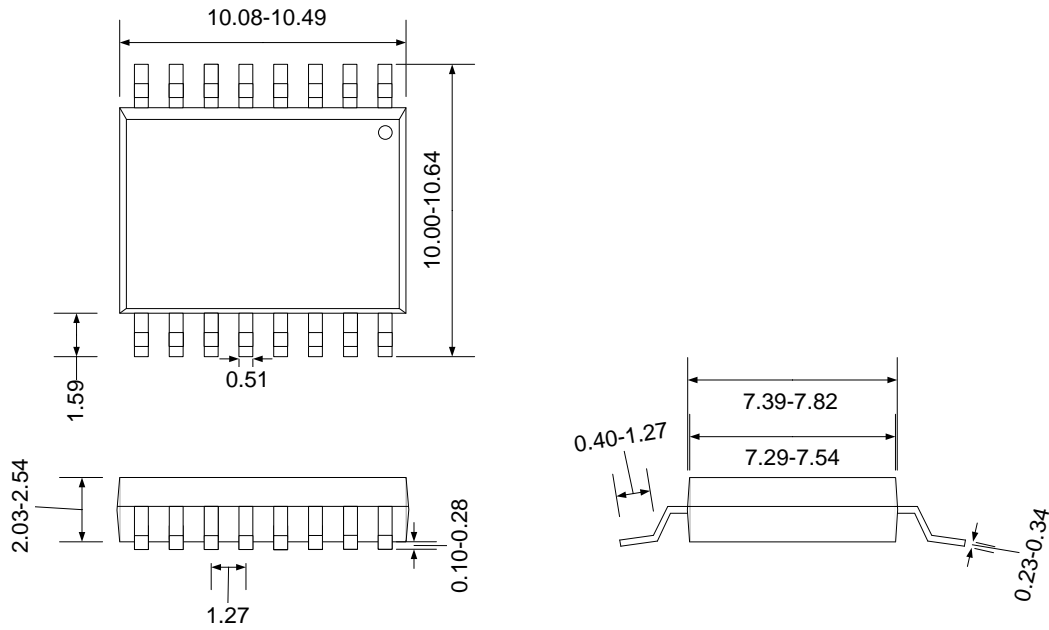

Figure 4: Waveform: propagation delay time, minimum pulse width (CLOCKB)

Ordering Information

Ordering Reference	Package	Temperature Range	Marking
CMT-744040A-PSOIC16-T	Plastic SOIC16	-55°C to +175°C	CMT-744040A

Package Dimensions



Drawing PSOIC16 (mm +/- 10%)

Contact & Ordering

CISSOID S.A.

Headquarters and contact EMEA:	CISSOID S.A. – Rue Francqui, 11 – 1435 Mont Saint Guibert - Belgium T : +32 10 48 92 10 - F: +32 10 88 98 75 Email: sales@cissoid.com
Sales Representatives:	Visit our website: http://www.cissoid.com

Disclaimer

Neither CISSOID, nor any of its directors, employees or affiliates make any representations or extend any warranties of any kind, either express or implied, including but not limited to warranties of merchantability, fitness for a particular purpose, and the absence of latent or other defects, whether or not discoverable. In no event shall CISSOID, its directors, employees and affiliates be liable for direct, indirect, special, incidental or consequential damages of any kind arising out of the use of its circuits and their documentation, even if they have been advised of the possibility of such a damage. The circuits are provided "as is". CISSOID has no obligation to provide maintenance, support, updates, or modifications.